

DI2CSB connection to passive device

The document describes connection of the DI2CSB Core to global I2C Bus and passive devices (LCD Driver, Memory etc.). It also illustrates a DI2CSB read from passive device and write to device timings.

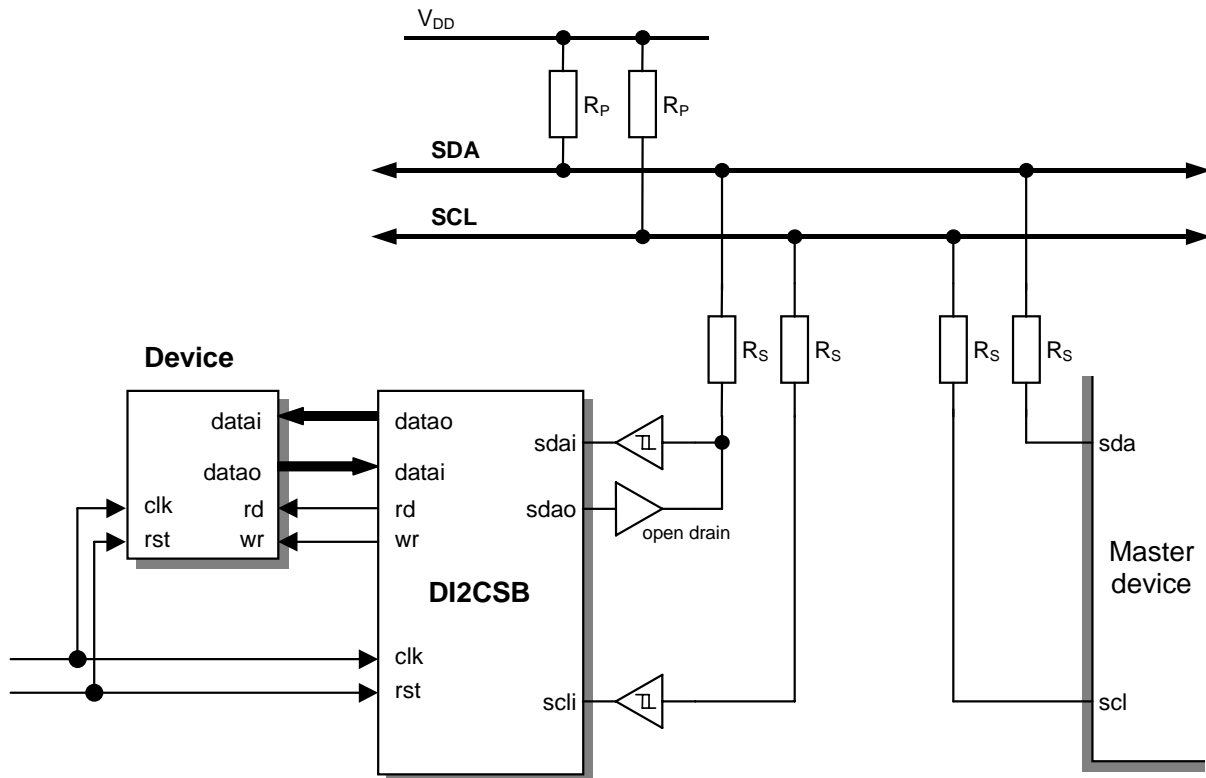

Connection DI2CSB to global I2C bus and a target device.

After completion of I2C data transfer the DI2CSB initiates a parallel data transfer to/from passive device. The figures below illustrate a parallel data read and write sequences.

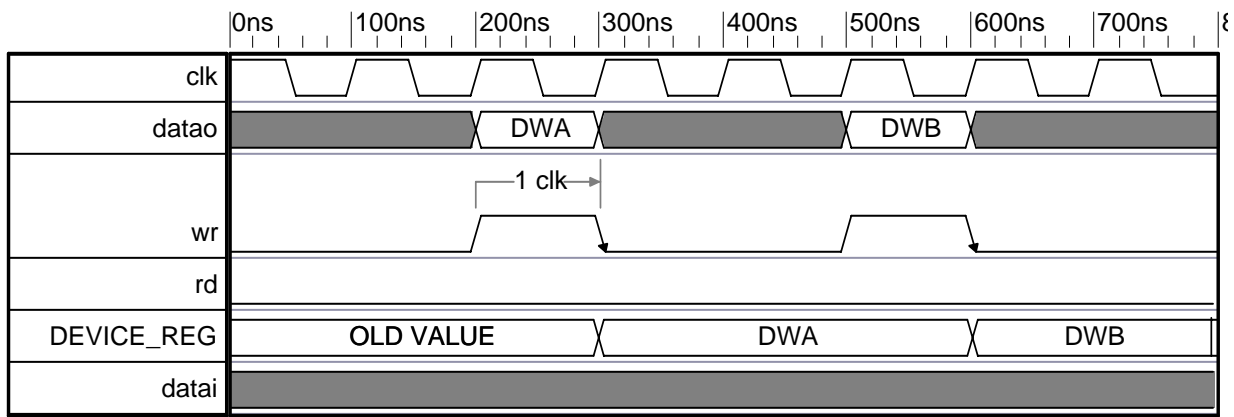

DI2CSB data write to device timing

Note: clk - system clock period
 datao - DI2CSB data output bus
 datai - DI2CSB data input bus
 DEVICE_REG - written register inside Device

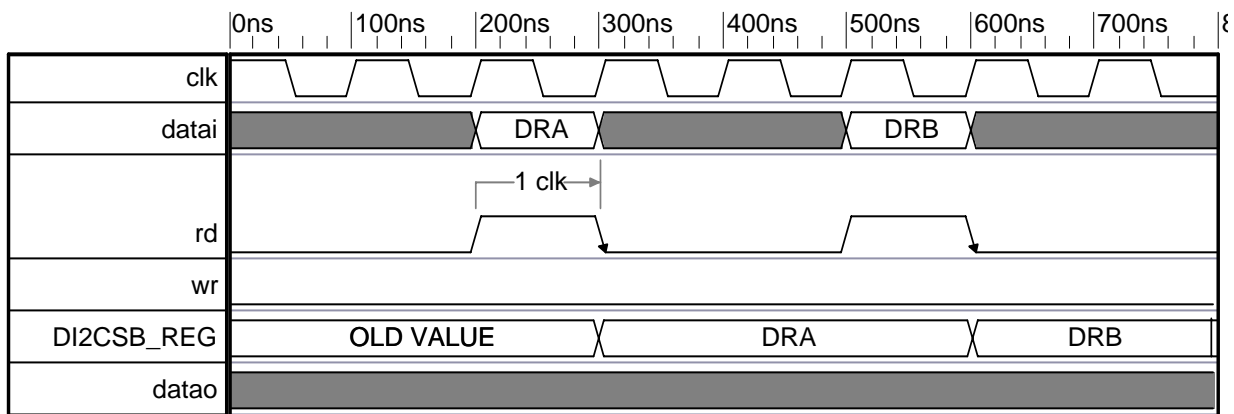

DI2CSB data read from device timing

Note: clk - system clock period
 datao - DI2CSB data output bus
 datai - DI2CSB data input bus
 DI2CSB_REG - written register inside DI2CSB