

DFPMU

Floating Point Coprocessor

v. 2.06

OVERVIEW

DFPMU is a Floating Point Coprocessor, designed to assist CPU in performing the floating point mathematic computations. DFPMU directly replaces C software functions, by equivalent, very fast hardware operations, which significantly accelerate system performance. It doesn't require any programming, so it also doesn't require any modifications to be made in the main software. Everything is done automatically, during software compilation, by the DFPMU C driver.

DFPMU was designed to operate with DCD's DP8051, but can also operate with any other 8-, 16- and 32-bit processor. Drivers for all popular 8051 C compilers are delivered together with the DFPMU package.

DFPMU uses the specialized CORDIC and standard algorithms, to compute math functions. It supports **addition, subtraction, multiplication, division, square root**, comparison, absolute value, change sign of a number and trigonometric functions: **sine, cosine, tangent** and **arctangent**. It has built-in conversion instructions from integer type to floating point type and vice versa. The input numbers format is compliant with IEEE-754 standard. DFPMU supports single precision real numbers, 16-bit and 32-bit integers. **Each floating point function can be turned on/off** at configuration level providing the flexible scalability of DFPMU module. It allows to save silicon space and provides exact configuration required by certain application.

DFPMU is a technology independent design, that can be implemented in a variety of process technologies.

APPLICATIONS

- Math coprocessors
- DSP algorithms
- Embedded arithmetic coprocessor
- Fast data processing & control

KEY FEATURES

- **Direct replacement** for C float software functions, such as: +, -, *, /, ==, !=, >=, <=, <, >
- Configurability of all available functions
- C interface supplied for all popular compilers: GNU C/C++, 8051 compilers
- No programming required
- IEEE-754 Single precision real format support – **float type**
- 16-bit word and 32-bit short integers format supported – **integer types**
- Flexible arguments and result registers location
- Performs the following functions:
 - *FADD, FSUB* – addition, subtraction
 - *FMUL, FDIV* – multiplication, division
 - *FSQRT* – square root
 - *FCHS, FABS* – change of sign, absolute value
 - *FXAM* – examine input data
 - *FUCOM* – comparison
 - *FSIN, FCOS* – sine, cosine
 - *FTAN* – tangent
 - *FATAN* – arctangent
 - *FILDW, FILD* – 16-bit, 32-bit integer to float
 - *FISTW, FIST* – float to 16-bit, 32-bit integer
- Exceptions built-in routines
- Masks each exception indicator:
 - *Precision lack PE*
 - *Underflow result UE*

- Overflow result OE
- Invalid operand IE
- Division by zero ZE
- Denormal operand DE
- Fully configurable
- Fully synthesizable, static synchronous design with no internal tri-states

DELIVERABLES

- ◆ Source code:
 - VHDL Source Code or/and
 - VERILOG Source Code or/and
 - Encrypted Netlist or/and
 - plain text EDIF netlist
- ◆ VHDL & VERILOG test bench environment
 - Active-HDL automatic simulation macros
 - NCSim automatic simulation macros
 - ModelSim automatic simulation macros
 - Tests with reference responses
- ◆ Technical documentation
 - Installation notes
 - HDL core specification
 - Datasheet
- ◆ Synthesis scripts
- ◆ Example application
- ◆ Technical support
 - IP Core implementation support
 - 3 months maintenance
 - Delivery the IP Core updates, minor and major versions changes
 - Delivery the documentation updates
 - Phone & email support

LICENSING

Comprehensible and clearly defined licensing methods, without royalty-per-chip fees, make using of IP Core easy and simple.

Single Site license option – it is dedicated for small and middle sized companies, running their business at one location.

Multi Sites license option – it is dedicated for corporate customers, running their business at several places. Licensed product can be used in selected company branches. In all cases, number of IP Core instantiation within a project and number of manufactured chips are unlimited.

The license is royalty-per-chip free. There is no restrictions regarding the time of use.

There are two formats of delivered IP Core

- VHDL, Verilog RTL synthesizable source code called HDL Source
- FPGA EDIF/NGO/NGD/QXP/VQM called Netlist

SYMBOL

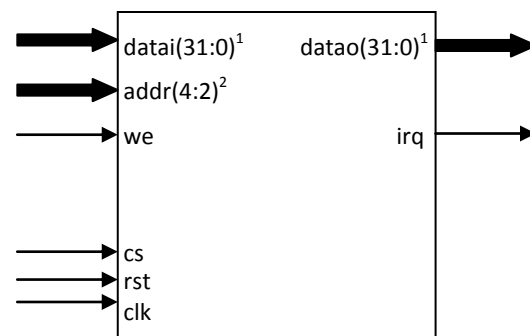

PINS DESCRIPTION

PIN	TYPE	DESCRIPTION
clk	Input	Global system clock
rst	Input	Global system reset
cs	Input	Chip select for read/write
datai[31:0]¹	Input	Data bus input
addr[4:2]²	Input	Register address to read/write
we	Input	Data write enable
datao[31:0]¹	Output	Data bus output
irq	Output	Interrupt request indicator

1 – data bus can be configured as 8-, 16- or 32- bit depends on processor's bus size

2 – address bus is aligned to work with 8- (3:0), 16- (3:1) or 32- (4:2) bit processors

BLOCK DIAGRAM

Mantissa – performs operations on mantissa part of number. The addition, subtraction, multiplication, division, square root, comparison and conversion operations, are executed in this module. It contains mantissas and work registers.

CORDIC – performs trigonometric operations on input data. The sine, cosine, tangent and arctangent operations are executed in this module. It contains three work registers.

Exponent – performs operations on exponent part of number. The addition, subtraction, shifting, comparison and conversion operations are executed in this module. It contains exponents and work registers.

Align – performs the numbers analysis against IEEE-754 standard compliance. Information about the data classes are passed as result, to appropriate internal module.

Shifter – performs mantissa shifting during normalization and denormalization operations. Information about shifted-out bits are stored for rounding process.

Control Unit – manages execution of all instructions and internal operation, required, to execute particular function.

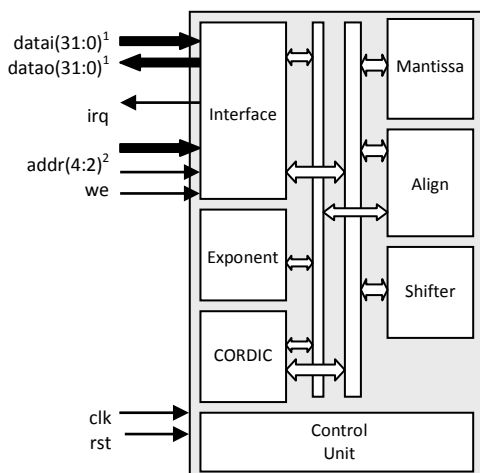

Interface – makes interface between external device and DFPMU internal 32-bit modules. It contains data, control and status registers. It can be configured to work with 8-, 16- and 32-bit processors.

PERFORMANCE

The following table gives a survey about the Core area and performance in the LATTICE® devices after Place & Route (all key features have been included):

Device	Speed grade	LUTs/PFUs	F _{max}
ORCA 4	-3	4464/ 711	30 MHz
ispXPGA	-5	5327/1393	42 MHz

Core performance in LATTICE® devices

IMPROVEMENTS

The tables and figures below illustrate the system with DFPMU performance improvements for two typical CPU. DFPMU floating point instructions performance, has been compared to standard C library functions, delivered with every commercial C compiler. Each program was executed in the same system environments. Number of clock periods were measured between input data loading into work registers and output result storing after operation. The results are shown in the table below. Improvement has been computed as a number of clock cycles, required by the CPU, to compute FP operation, by the number of clocks required to compute the same operation by system of CPU with DFPMU:

$$improvement = \frac{CPU_clocks}{CPU + DFPMU_clocks}$$

More details are available in the core documentation.

The following table gives a survey about the DP8051+DFPMU performance, compared to standard 8051 microcontroller.

Device	Improvement
80C51	1.0
DP8051	7.3
DP8051+DFPMU	162.0

General performance improvements

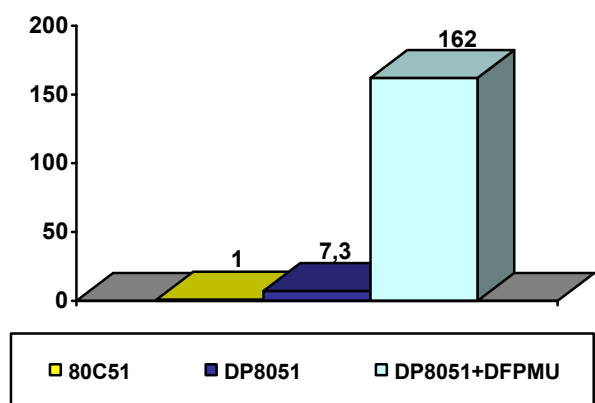



IEEE-754 FP Instruction	Improvement
Addition	73
Subtraction	60
Multiplication	65
Division	182
Square Root	392
Sine	139
Cosine	144
Tangent	222
Arcs Tangent	182
Average speed improvement:	162

Improvements of particular operations

IEEE-754 FP Instruction	Improvement
Addition	6.4
Subtraction	6.5
Multiplication	5.1
Division	6.5
Square Root	12.9
Sine	40.8
Cosine	41.3
Tangent	65.0
Arcs Tangent	49.6
Average speed improvement:	28.3

Improvements of particular operations

More details are available in the core documentation.

The table below shows performance improvements of the sample 32bit-RISC CPU with DFPMU, compared to the same system without the DFPMU coprocessor.

Device	Improvement
CPU	1.0
CPU+DFPMU (arithmetic)	7.5
CPU+DFPMU (trigonometric)	49.2
CPU+DFPMU (overall)	28.3

General performance improvements

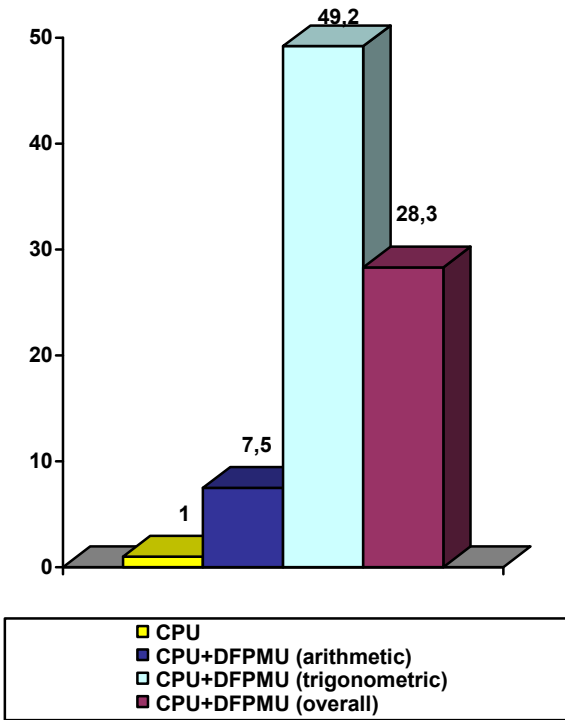



CONTACT

For any modification or special request, please contact Digital Core Design or local distributors.

Headquarters:

Wroclawska 94

41-902 Bytom, POLAND

e-mail: : info@dcd.pl

tel. : +48 32 282 82 66

fax : +48 32 282 74 37

Distributors:

Please check: <http://dcd.pl/sales/>