

D68000

16/32-bit Microprocessor

v. 1.20

OVERVIEW

D68000 soft core is binary - compatible with the industry standard 68000 32-bit microcontroller. D68000 has a 16-bit data bus and 27-bit address data bus. It is code compatible with the MC68008 and is upward code compatible with the MC68010 virtual extensions and the MC68020, 32-bit implementation of the architecture. D68000 has improved instructions set, which allows execution of a program with higher performance, than standard 68000 core. It contains built-in **DoCD™ debugger** interface. D68000 is delivered with **fully automated testbench** and **complete set of tests**, allowing easy package validation at each stage of SoC design flow.

KEY FEATURES

- Software compatible with industry standard 68000
 - DoCD - BDM on-chip debugger
 - MULS, MULU take 28 clock periods
 - DIVS, DIVU take 28 clock periods
 - Optimized shifts and rotations
 - Idle cycles removed to improve performance
 - Shorter effective address calculation time
 - Bus cycle timings identical to 68000
 - 32 bit data and address registers
 - 14 addressing modes:
 - *Direct:*
 - *Data register direct*
 - *Address register direct*
 - *Indirect:*
 - *Register indirect*
 - *Postincrement register indirect*
 - *Predecrement register indirect*
 - *Register indirect with offset*
 - *Indexed register indirect with offset*
- *PC relative:*
 - *Relative with offset*
 - *Relative with index and offset*
 - *Absolute data:*
 - *Absolute short*
 - *Absolute long*
 - *Immediate data:*
 - *Immediate*
 - *Quick immediate*
 - *Implied*
 - 5 data types supported:
 - *bits*
 - *BCD*
 - *bytes, words and long words*
 - Arithmetic Logic Unit includes:
 - *8,16,32-bit arithmetic & logical operations*
 - *16x16 bit signed and unsigned multiplication*
 - *32/16 bit signed and unsigned division*
 - *Boolean operations*
 - Interrupt controller:
 - *7 priority levels interrupt controller*
 - *Unlimited number of virtual interrupt sources*
 - *Vectored and auto-vectored modes*
 - Memory interface includes:
 - *Up to 256 MB of address space*
 - *16-bit data bus*
 - *Asynchronous bus control*
 - M6800 family synchronous interface
 - 3- and 2- wire bus arbitration
 - Supervisor and user modes
 - Fully synthesizable, static synchronous design with no internal tri-states

DoCD-BDM debugger

D68000 DoCD-BDM is a hardware debugger, which provides debugging capability of a whole SoC system. Its main features are summarized below.

- 100% compatible with BDM debug interfaces
- Works with industry BDM interfaces/cables
 - Public Domain cable
 - Macraigor Wiggler
 - P&E BDM cable
- Fully supported by standard debugging tools:
 - GNU GDB debugger
 - Cosmic ZAP debugger
 - Tasking debugger

SYMBOL

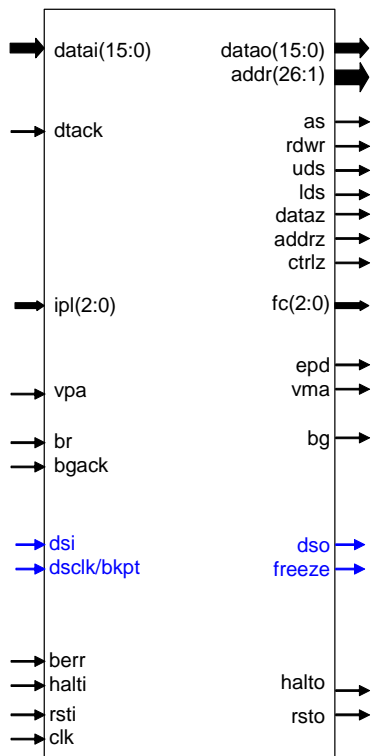

PINS DESCRIPTION

PIN	TYPE	ACTIVE	DESCRIPTION
clk	input	high	Global clock
rsti	input	low	Global reset input
halti	input	low	Halt input
vpa	input	low	Valid peripheral address

ipl[2:0]	input	low	Interrupt control
dtack	input	low	Data transfer acknowledge
br	input	low	Bus request
bgack	input	low	Bus grant acknowledge
datai[15:0]	input	-	Data bus input
berr	input	low	Bus error
dsi	input	-	DoCD-DBM serial interface data input
dsclk/bkpt	input	low	DoCD-DBM serial interface data clock input / breakpoint
dso	output	-	DoCD-DBM serial interface data output
freeze	output	high	CPU is frozen by DoCD-DBM
datao[15:0]	output	-	Data bus output
addr[26:1]	output	-	Address data bus
bg	output	low	Bus grant
as	output	low	Address strobe
rdwr	output	high/low	Read write signal
uds	output	low	Upper data byte strobe
lds	output	low	Lower data byte strobe
addrz	output	high	Turns Address bus into 'Z' state
dataz	output	high	Turns Data bus into 'Z' state
ctrlz	output	high	Turns as, rdwr, uds, lds, vma, fc(2:0) signals into 'Z' state
fc[2:0]	output	high	Processor function code
epd	output	high	Enable peripheral device
vma	output	low	Valid memory address
halto	output	low	Halt output
rsto	output	low	Reset output

DELIVERABLES

- ◆ Source code:
 - VHDL Source Code or/and
 - VERILOG Source Code or/and
 - Encrypted, or plain text EDIF netlist
- ◆ VHDL & VERILOG test bench environment
 - Active-HDL automatic simulation macros
 - ModelSim automatic simulation macros
 - NC-Sim automatic simulation macros
 - Tests with reference responses
- ◆ Technical documentation
 - Installation notes
 - HDL core specification
 - Datasheet
- ◆ Synthesis scripts
- ◆ Example application
- ◆ Technical support
 - IP Core implementation support

- 3 months maintenance
 - Delivery the IP Core updates, minor and major versions changes
 - Delivery the documentation updates
 - Phone & email support

LICENSING

Comprehensible and clearly defined licensing methods, without royalty-per-chip fees, make using of IP Core easy and simple.

Single Site license option – it is dedicated for small and middle sized companies, running their business at one location.

Multi Sites license option – it is dedicated for corporate customers, running their business at several places. Licensed product can be used in selected company branches.

In all cases, number of IP Core instantiation within a project and number of manufactured chips are unlimited. The license is royalty-per-chip free. There is no restrictions regarding the time of use.

There are two formats of delivered IP Core

- VHDL, Verilog RTL synthesizable source code called HDL Source
- FPGA EDIF/NGO/NGD/QXP/VQM called Netlist

BLOCK DIAGRAM

ALU – Arithmetic Logic Unit performs the arithmetic and logic operations, during execution of an instruction. It contains accumulator and related logic, such as arithmetic unit, logic unit, multiplier and divider. BCD operation are executed in this unit and condition code flags (N-negative, Z-zero, C-carry V-overflow) for most instructions.

Shifter – Performs shifting operations for the appropriate instructions, mainly for rotation, shift and bit operations.

Control Unit – Performs the core synchronization and data flow control. This module manages execution of all instructions. Contains SR (status register is consisted of two portions: supervisor byte and user byte) and its related logic.

Opcode Decoder – Performs an instruction opcode decoding and the control functions for all blocks.

Memory Interface – Contains memory access related registers. It performs the memory addressing instructions code fetching and data transfers. It is responsible for all external bus cycle actions, such as: read & write, repeated read & write, halt and resume of bus cycles, bus arbitration provided by 3- and 2- wire system, correct bus and address errors handling, wait states cycle insertion and M6800 synchronous cycle generation.

Interrupt Controller – Interrupt Control module is responsible for the interrupt manage system for the external & internal interrupts and exceptions processing. It manages auto-vectored interrupt cycles, priority resolving and correct vector numbers creation.

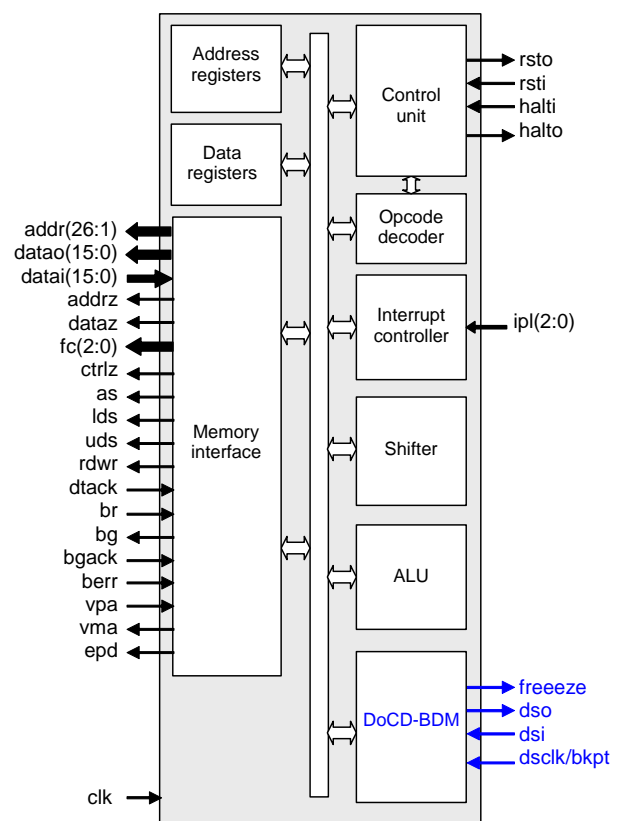

Address registers – Contains 32-bit A0 to A6 address registers, two stack pointers USP (user SP) and SSP (Supervisor SP), 32-bit Program counter and related logic to perform word and long address operations. Effective address operations are executed in this unit.



Data registers – Contains 32-bit data registers D0 to D7 and related logic to perform byte, word and long data operations.

DoCD-DBM – it’s a hardware debugger, which provides debugging capability of a whole SoC system. Unlike other on-chip debuggers, DoCD-BDM provides non-intrusive debugging of running application. It can halt, run, step into or skip an instruction, patch user code, read/write any contents of micro-processor including all registers, memories and user connected peripherals. Hardware breakpoints can be set and controlled on program and data memories. One additional pin FREEZE, indicates the state of the CPU. It is active, when CPU is halted and debugger is in action. The DoCD-BDM system includes **SPI-like serial interface** and complete set of tools, to communicate and work with core in a real time debugging. When debugger is not used, it is automatically switched to power save mode. Finally, when debug option is no longer used, whole debugger is turned off.

PERFORMANCE

The following table gives a survey about the Core area and performance in the XILINX® devices after Place & Route (all key features have been included):

Device	Speed grade	Slices	F _{max}
VIRTEX	-6	3356	32 MHz
VIRTEX-E	-8	3317	38 MHz
VIRTEX-II	-5	3366	58 MHz
VIRTEX-IIP	-7	3415	65 MHz

Core performance in XILINX® devices



CONTACT

For any modification or special request, please contact Digital Core Design or local distributors.

Headquarters:

Wroclawska 94

41-902 Bytom, POLAND

e-mail: : info@dcd.pl

tel. : +48 32 282 82 66

fax : +48 32 282 74 37

Distributors:

Please check: <http://dcd.pl/sales/>